

MONK

Sushi Conveyors

回
轉
壽
司

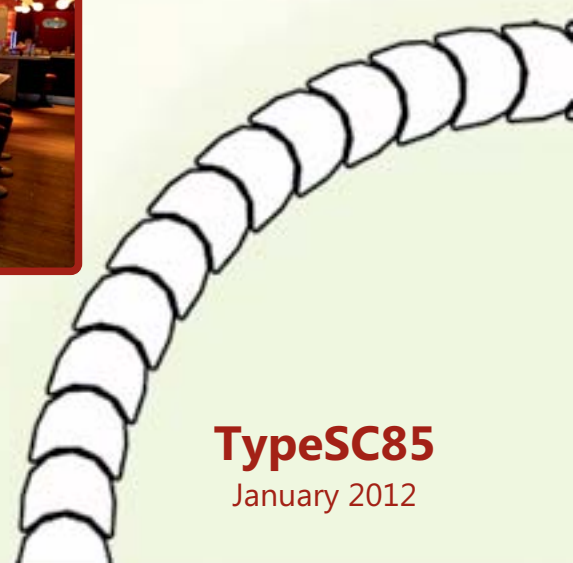

TypeSC85
January 2012

How to Start

The following is a basic guide to help you with the first steps when purchasing a sushi conveyor. Don't be afraid to send us the best information that you have at the moment with a view of making changes later, we know that plans change and we are happy to re-quote you as plans for your restaurant change. The most important factor is that we are both happy with the final layout before manufacturing starts.

1. First decide on the number of covers that you will need to make your restaurant profitable.
2. How many customers will be seated at the conveyor counter and how many will be seated at booth tables.
3. Choose a layout from those shown on the next page and let us know the 'L' dimensions. Don't worry if the layout or dimensions change later we can easily update our quotation.
4. If possible send us a drawing showing the layout of your restaurant.
5. We will then produce a provisional drawing and quotation.
6. Our provisional quotation will have separate prices for all of the main components. You can then decide if you want to order the complete system from us or just the conveyor or conveyor and support frame and finish the remainder of the system yourself. It is perfectly acceptable to us if you only order the conveyor, some of our customers will do this if they are working with a small budget.
7. Visit us if it is possible, we will welcome the opportunity to show you the many options that are available. We can also visit a restaurant where we have a conveyor installed. Our factory is only 45 minutes from London on the train. In London you will be able to visit many different restaurants and gain many ideas.
8. Once we have arrived at the final specification and quotation and assuming that you place your order with us we will start the manufacture of your sushi conveyor. This normally takes 5 to 8 weeks depending on the design of the conveyor and if there are any special features such as unusual angles bends, curves etc. Once the conveyor is finished you are most welcome to visit us and inspect it before delivery.
9. We will then arrange a convenient day to deliver and install the conveyor. Full installation and commissioning will be included and our engineers will carry out the following tasks:

Unloading of the lorry.

Unpacking the shipping crate and inspecting the conveyor.

Assembly of the support frame, conveyor, cladding, Corian counters.

Wiring the Motor to the speed controller.

Fitting and checking the free running of the chain.

Test running the system.

Final hand over and signing off.

This list may vary and is subject to the design of the system.

10. We suggest that our engineer returns after the conveyor has been running for 3 months to check that it is running correctly. This is included in the original cost of the conveyor for the UK and offered as a chargeable option outside the UK.

Layout Options for the Twin Lane Sushi Conveyor

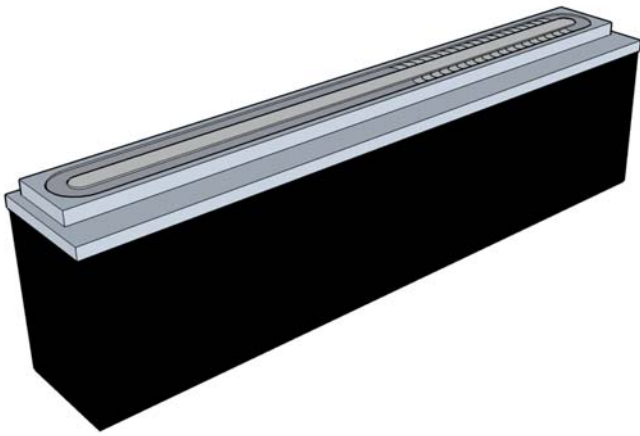

SC85T-001 Basic straight sushi conveyor, can be easily positioned in a restaurant. It is Ideal for the start-up or smaller restaurant. Footrests can be added as part of the construction. Can easily be extended in the future with the addition of our standard modular sections. Customer counters can be supplied in Corian acrylic, granite,

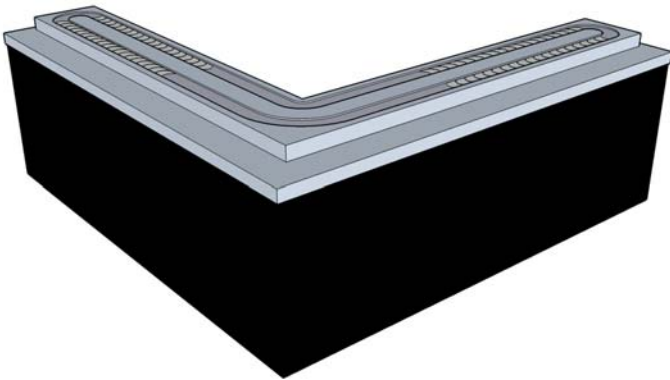

SC85T-002 A right angle 'L' twin lane conveyor layout can be very efficient in certain restaurants. It can be easily be positioned to maximise the seating arrangements.

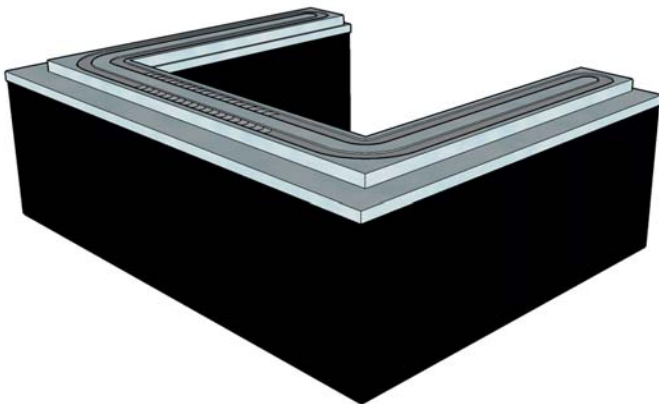

SC85T-003 A 'U' shape twin lane conveyor layout can enable you to position the food preparation area so that it can be viewed by customers. The conveyor can be easily be positioned to maximise the seating arrangements.

Sushi Conveyor Components

Below are detailed descriptions of the items listed in our quotations.

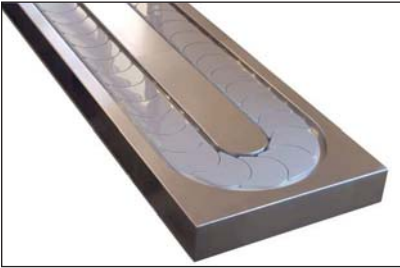

ITEM 1. CONVEYOR WITH VARIABLE SPEED DRIVE:

Our conveyor is manufactured in stainless steel with a pleasing polished hairline finish. Our system is designed as a set of standard modules that can be fitted together to create a layout to suit your restaurant. The main modules are drives, idlers, straight sections in 2.4m, 1.8, 1.2m and 0.6m lengths, right angle bends and 'tees'. The crescent chain is 85mm wide with a pitch of 63.5mm (2.5"). It is manufactured to a unique design in a certified food grade plastic. Each chain pin has a roller that follows the plastic guides in the conveyor body, this makes the chain very smooth running and extremely quiet. It also enables corners to be made without sprocket wheels and also allows us to make complicated special curved conveyors.



ITEM 2. SUPPORT FRAME:

Our sushi conveyor support frame is constructed from our anodised extruded aluminium alloy called MONEX⁴⁰. This is a very robust frame building system. Beams are 80mm x 40mm and 40mm square. Legs are spaced at 1m pitch and each leg has a 40mm diameter adjustable foot to enable the frame to be accurately levelled. The frame can be bonded or bolted to the floor using our heavy duty powder coated steel brackets. This is a very reliable, robust and hygienic system, the design ensures a very quick install time.



ITEM 3. COUNTER SUPPORTS:

Our counter supports are made of 10mm thick x 150mm wide solid steel. It is very important that customer counters are supported properly so that the counters are rigid. These are fitted at the top of each leg assembly at 1m pitch. They are powder coated in white polyester gloss.



ITEM 4. OPAL ACRYLIC CLADDING:

There are many materials that can be used for the cladding of the conveyor frame. The most popular material is 10mm thick white acrylic. This has a very pleasing gloss finish, is very strong and has the option of being illuminated from behind. Panels are clamped in place by powder coated aluminium sections. They are also easily removable to allow access to services and lights.



ITEM 5. KICKBOARD:

Below the cladding is a kickboard 150mm high with a simulated stainless steel finish. This is a very tough material and resists marking when cleaning the floor or from customers shoes. It has a seal that contacts the floor to improve hygiene under the conveyor.

Sushi Conveyor Components

Below are detailed descriptions of the items listed in our quotations.



ITEM 6. CLADDING LIGHTING:

Two types of lighting are used on our conveyors to illuminate the cladding panels. Fluorescent lighting is a common option, it is reasonably inexpensive to install.

LED tubes are more expensive but use less power so are much cheaper to run and will save you money over their lifetime (up to 80,000hours). They also have the advantages of a bright pure light, no flicker, no RF interference and they don't use mercury so are the most 'green' lights to use.



ITEM 7. COUNTERS:

Customer counters are normally supplied in 'Corian' solid acrylic surface, 400mm to 450mm wide with a 50mm deep edge. The photo shows 'Glacier White'. Many other colours are available.

Counters can also be supplied in other materials such as granite, marble, wood and glass.



ITEM 8. BOOTH TABLES:

Booth tables for four or six people are supplied to the same specification as the counters. The tables are fixed to the side of the conveyor with a heavy steel bracket. The outside end is supported from the floor with a stainless steel leg.

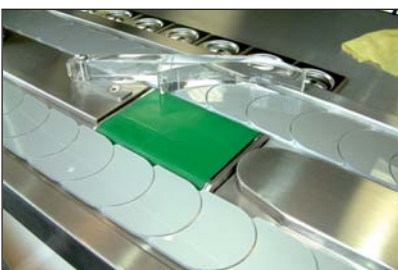

ITEM 9. CROSSOVER UNIT:

On larger systems it is wise to use a crossover unit to effectively shorten the path of the sushi on the conveyor when the restaurant is not full. It comprises a small conveyor positioned between the two belts on a twin lane system. It has a moveable guide to divert the plates when required.



ITEM 10. TUBULAR SUPPORT STAND:

An alternative to the full base frame and cladding is our single leg stands, these can be supplied in painted steel or polished stainless steel and are securely bolted to the floor. The conveyor is fitted to a 40 x 80mm support frame. They enable the floor to be easily cleaned so are very hygienic.

Sushi Conveyor Profiles

SC85 Standard Profile - Chain Width 85mm

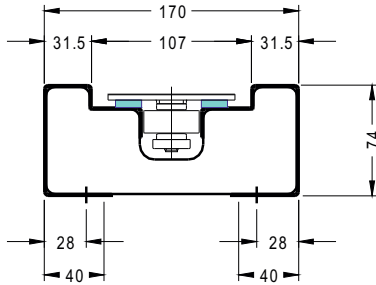

SC85S-170

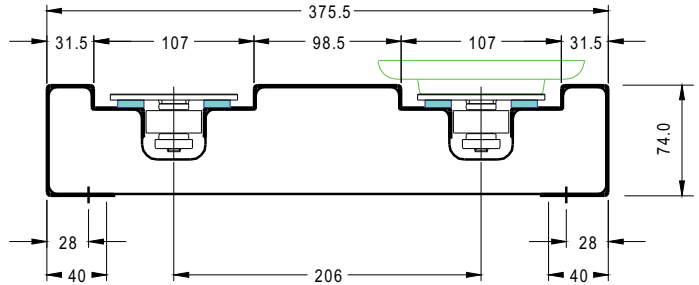

SC85T-376

SC85 Slim Line Profile - Chain Width 85mm

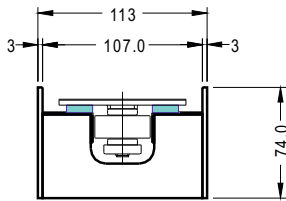

SC85S-113

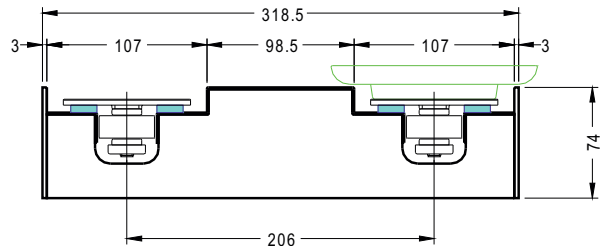

SC85T-319

SC114 Large Profile - Chain Width 114mm

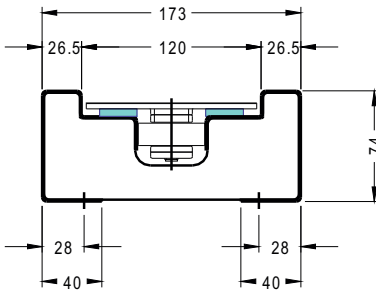

SC114S-173

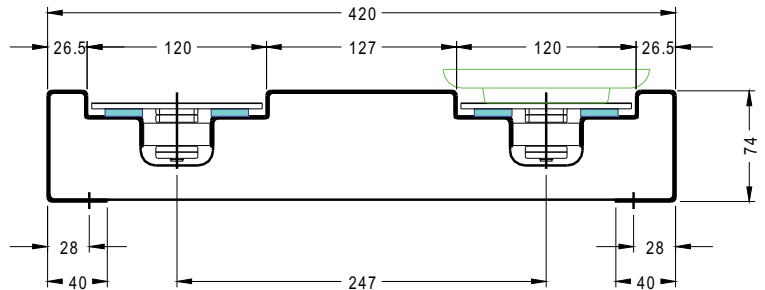

SC114T-420

SC114 Large Profile - Chain Width 114mm

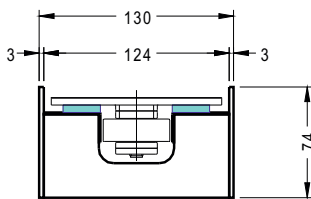

SC114S-130

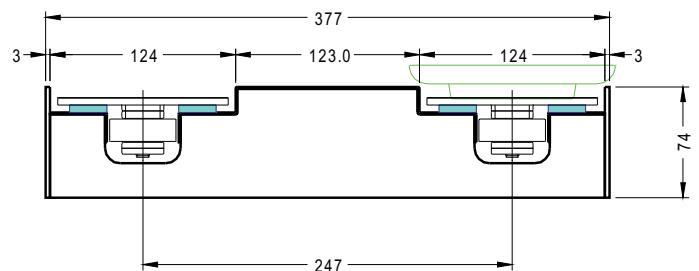

SC114T-377

Sushi Conveyor Modules

Type SC85T-375 Sushi Conveyor, 85mm Chain, twin lane.

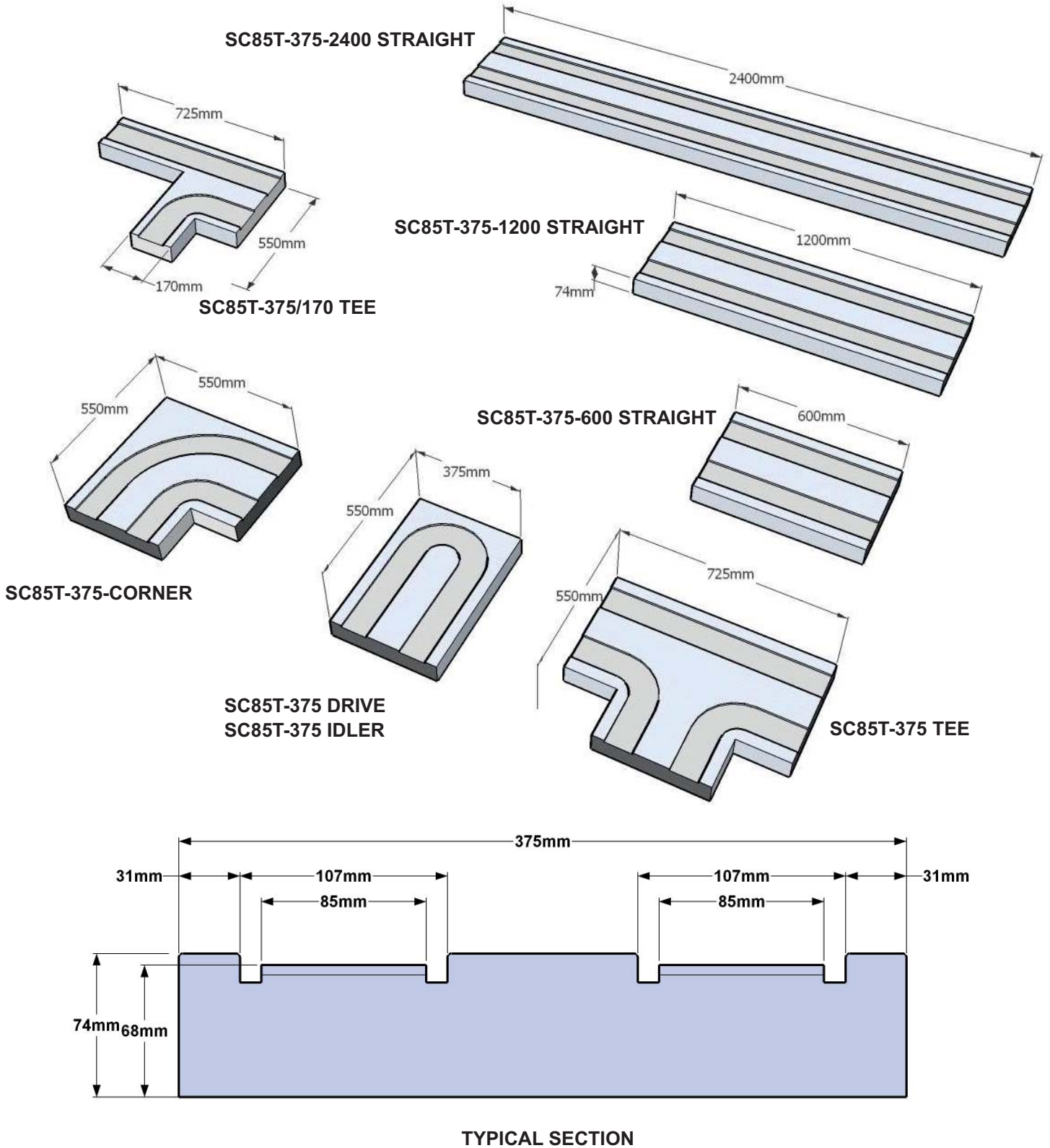

Sushi Conveyor Modules

Type SC85S-170 Sushi Conveyor, 85mm Chain, single lane.

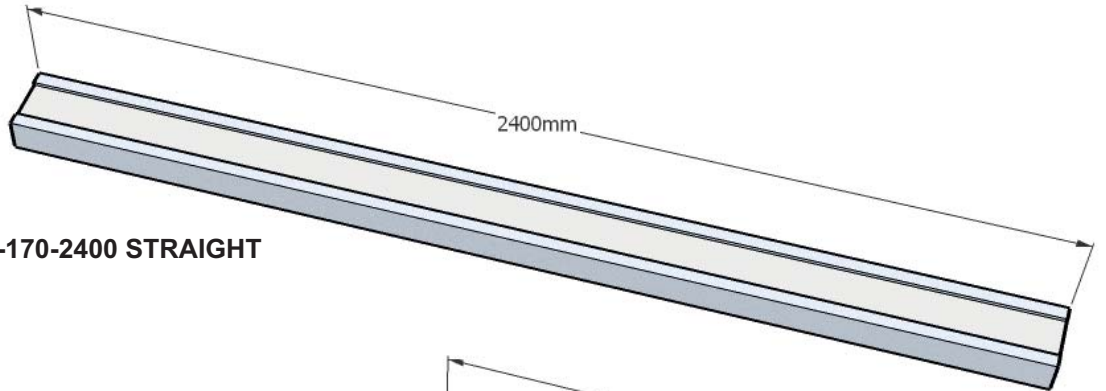

SC85S-170-2400 STRAIGHT

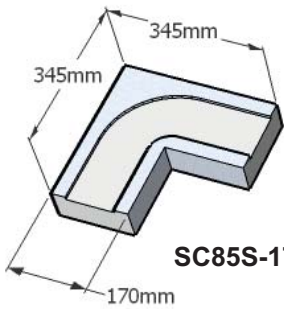

SC85S-170-CORNER

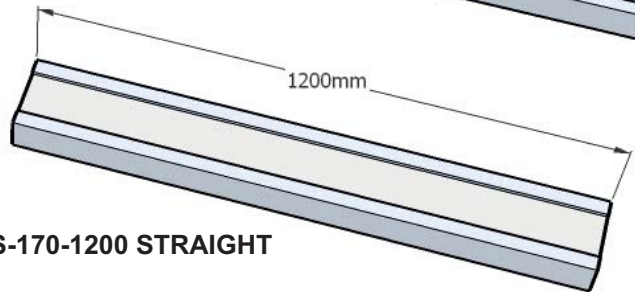

SC85S-170-1200 STRAIGHT

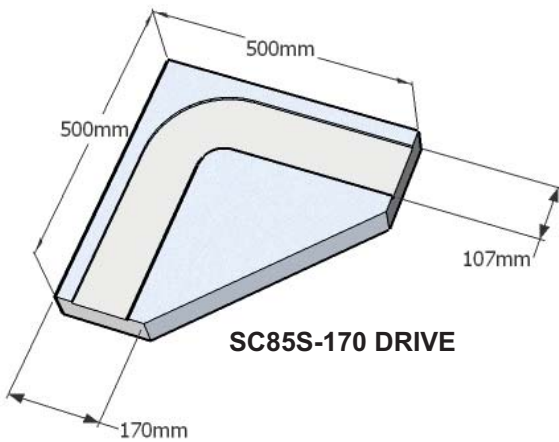

SC85S-170 DRIVE

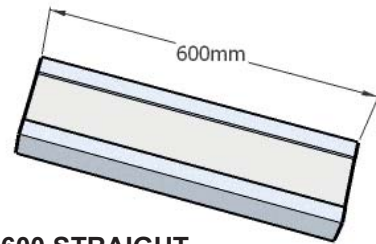

SC85S-170-600 STRAIGHT

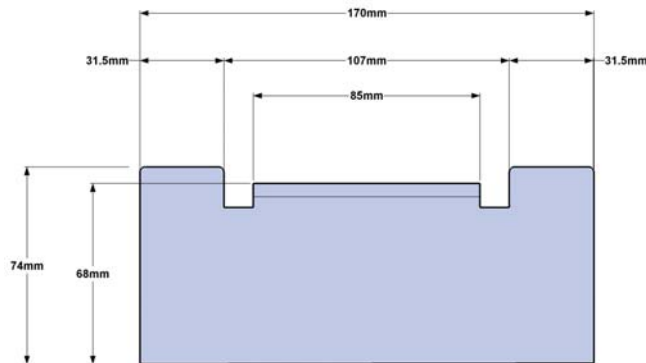

TYPICAL SECTION

Sushi Conveyor Special Options

Island End with Overhead Lighting Type SC85-ISL-032

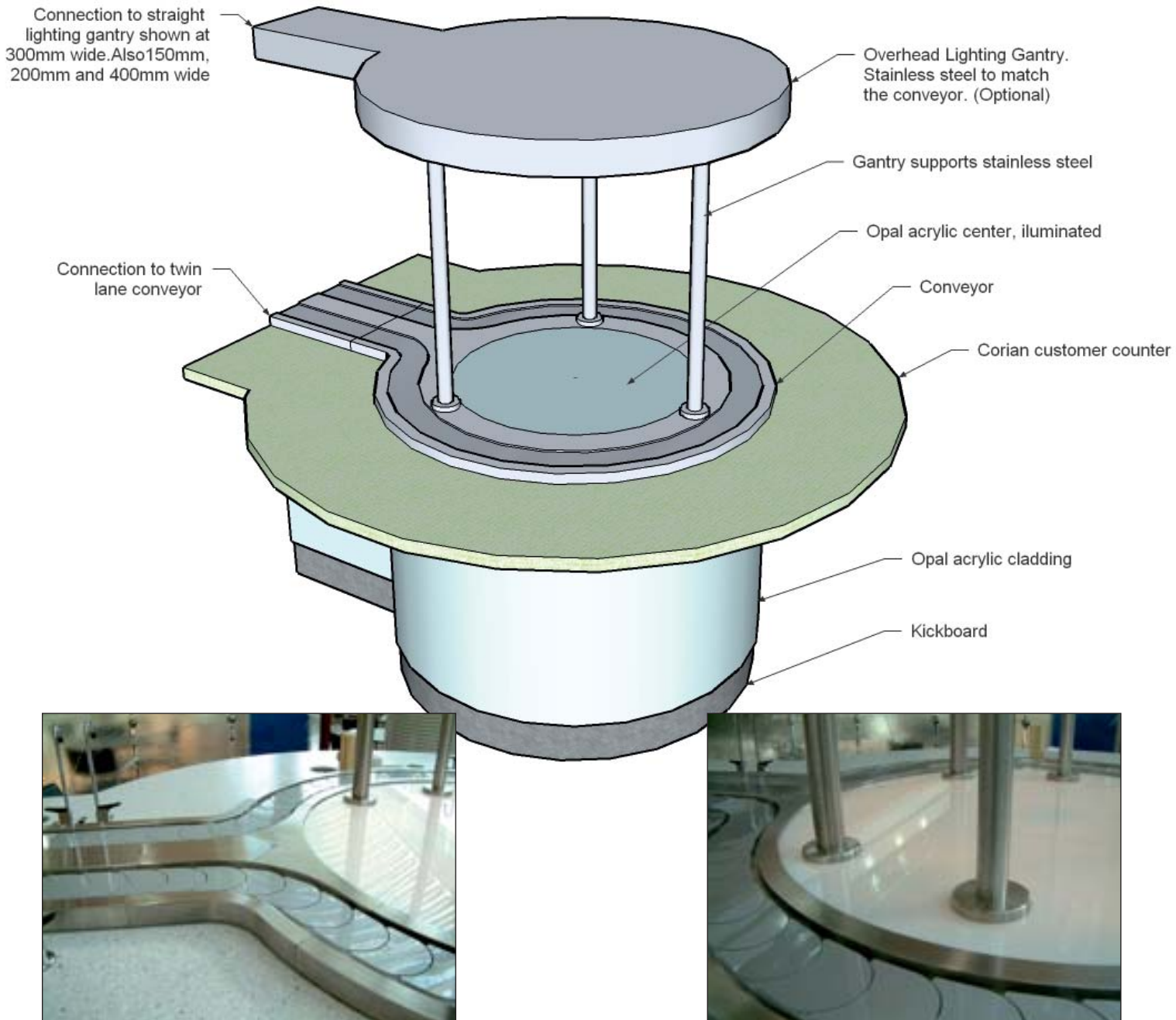

- Our Island End is a very attractive addition to any sushi restaurant.
- It enables more customers to be seated at the end of a conveyor.
- Our overhead lighting system is fitted.
- All wiring is hidden from view, installed inside the housing and supports.
- We can fit many different types of lights: Halogen or low energy spotlights, pendent lights to suit you décor.
- Center area can be made into a unique feature.

Examples of recent installations - on a 1m grid

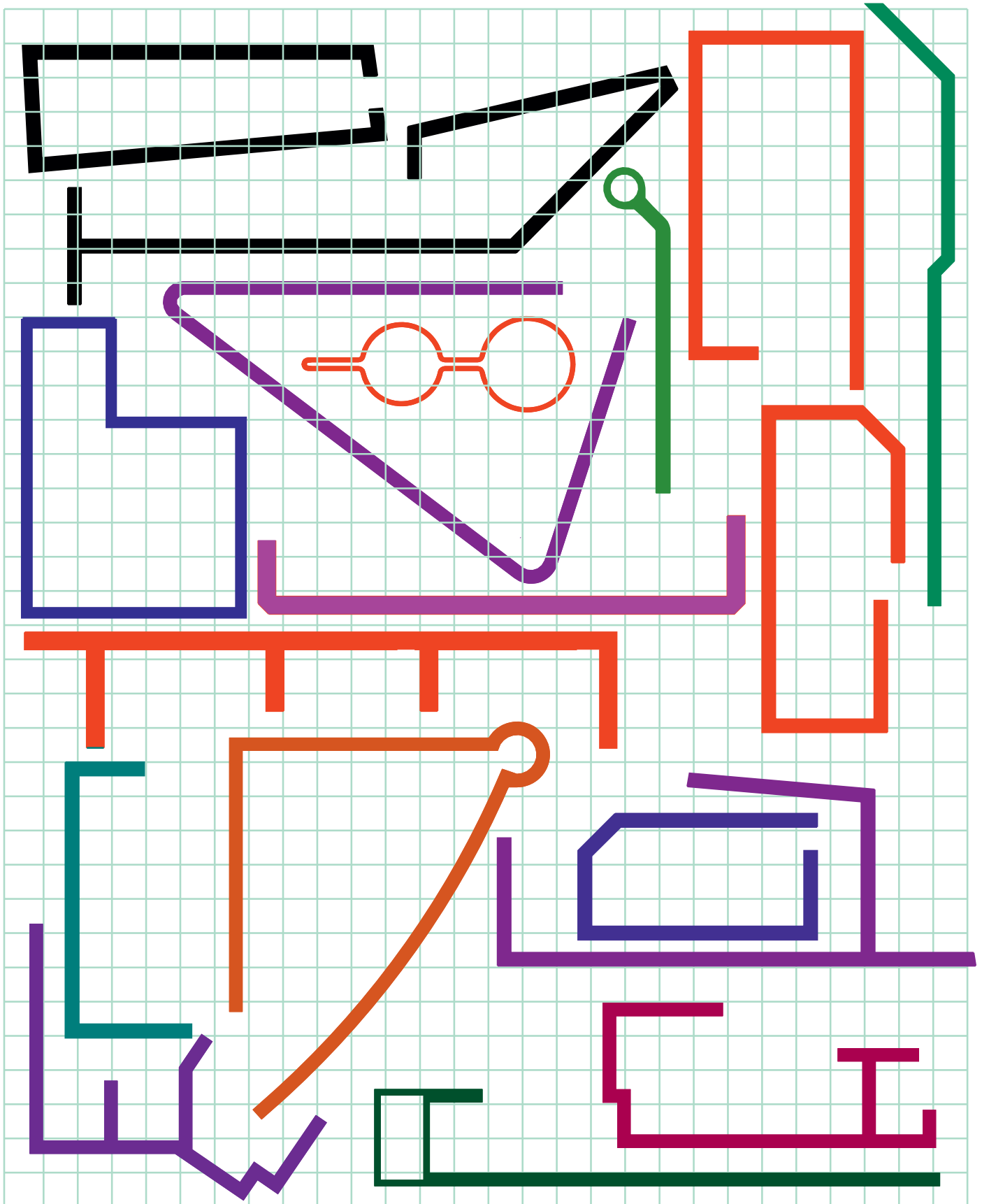

Plates & Dishes

For the best presentation of sushi, we can supply you with a range of products in a variety of colours and patterns. Moulded in Melamine they are unbreakable in normal use and dishwasher proof.

**Sushi Plate T14022W**

White Sushi Plate with coloured outside and rim in blue, green, orange, pink, red & yellow. 140mm diameter x 23mm high. Minimum order per colour 60

**Sushi Dish T L14038W**

White Sushi Bowl with coloured outside and rim in blue, green, orange, pink, red & yellow. 140mm diameter x 23mm high. Minimum order per colour 60

**Lid TC180L**

Clear PC Lid for Sushi Plates Re-usable can be washed in a dishwasher. 130 x 58mm. Minimum order 100

**Sushi Bowl T590W**

White Melamine Sushi Bowl with coloured outside and rim in blue, green, orange, pink, red & yellow. 140mm diameter x 520ml capacity. Minimum order per colour 20

**Plate TB1840CL**

Black & Claret Round Plate 255mm diameter. Minimum order 30

**Dipping Dish T2995**

White Dipping Dish 95 x 20mm. Minimum order 72

**Ellipse Bowl T6003 & TB6003**

Ellipse Small Bowl in black or white 156 x 145 x 47mm. Minimum order 60

**Sushi Bowl TB1810CL**

Black & Claret Round Bowl 110 x 55mm. Minimum order 40

**Sushi Platter T908 & TB908**

Rectangular Platter in white or black 285 x 180mm. Minimum order 20

**Spoon T6020 & TB6020**

Chinese Soup Spoon in Black or white 140mm. Minimum order 60

MONK

Sushi Conveyors for Hire

回
轉
壽
司

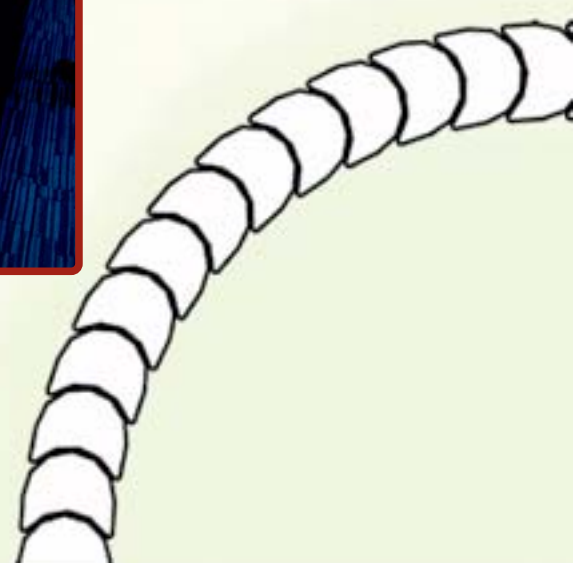

Perfect for:

Sushi - Tapas - Drinks - Products - Samples

Sushi Conveyors For Hire



Add some movement to your party, wedding reception or promotional event. There are six layouts to choose from so that you can choose a conveyor to suit the space available. Our portable sushi conveyor system is easy to transport and can be setup quickly. It makes a very professional, completely free standing sushi conveyor system. The conveyor has a silver crescent chain and a satin polished stainless steel body. It is situated on a stainless steel support table with folding legs. The sides have a wrap-round flexible cover. There is a choice of colours and the option to have the cover printed with your logo or



Parties - Just like in a Sushi Restaurant with a sushi conveyor belt, our portable conveyor can be the centre piece to your party moving food or drinks. You will find people can't



Serving Drinks - The efficient way of serving drinks at a function. Fully load the conveyor with drinks before your guests enter the function room so that everyone can be



Buffet - Perfect for wedding receptions, parties, corporate functions. Impress your guests with a moving selection of food.



Products - Making your products stand out of the crowd at an exhibition or promotional event can be difficult. Movement catches peoples attention and draws them in to look at your products. Watches, Lady's shoes, mobile phones to baseball caps, they have all been promoted using one of our portable conveyors.

Portable Sushi Conveyor for Hire

Choose from one of the following layouts for your portable sushi conveyor. We will deliver & set up the sushi conveyor at your chosen location. Our conveyors come in easily movable sections, transported in lightweight padded bags so access to rooms upstairs or in lifts is not a problem.

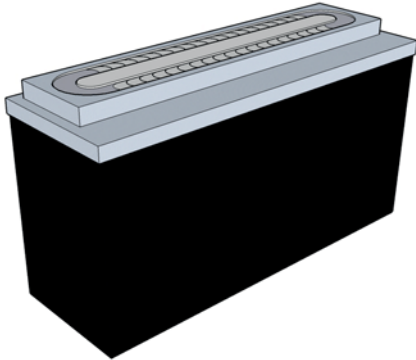

Layout T1. 1.800mm long, 600mm wide, 975mm to the floor.
Capacity 20 plates. Delivered in one unit.

Stainless steel single or twin lane sushi conveyor.
Crescent chain with silver gloss surface.
Variable speed controller.
Stainless steel support system.
Wrap round base cover. Can be printed to your design.
Sections locked together using a single tool.
Special layouts & lengths available.
Reduced rates for longer hire periods available.

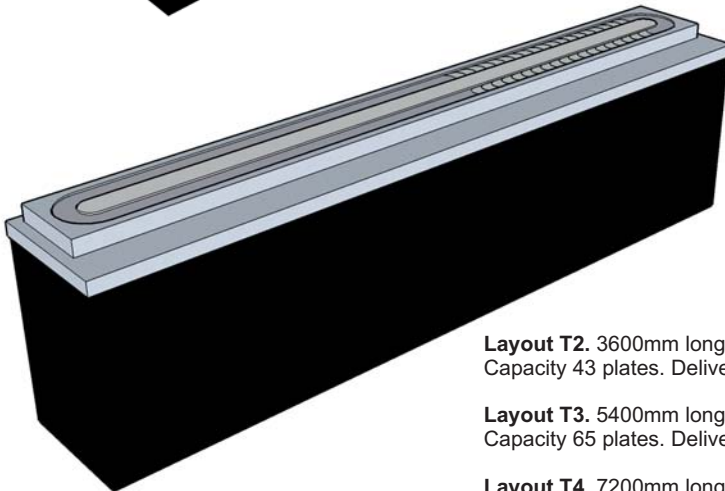

Layout T2. 3600mm long, 600mm wide, 975mm to the floor.
Capacity 43 plates. Delivered in two units.

Layout T3. 5400mm long, 600mm wide, 975mm to the floor.
Capacity 65 plates. Delivered in three units.

Layout T4. 7200mm long, 600mm wide, 975mm to the floor.
Capacity 88 plates. Delivered in four units.

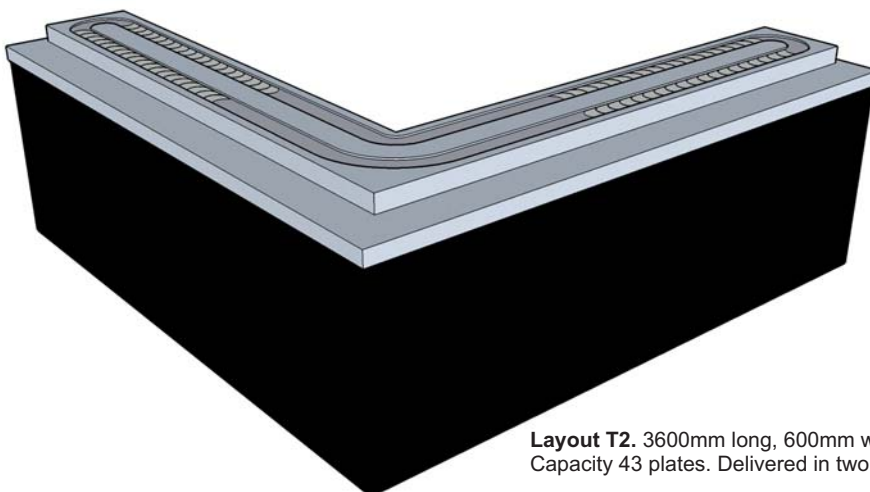

Layout T2. 3600mm long, 600mm wide, 975mm to the floor.
Capacity 43 plates. Delivered in two units.

Layout T3. 5400mm long, 600mm wide, 975mm to the floor.
Capacity 65 plates. Delivered in three units.

Layout T4. 7200mm long, 600mm wide, 975mm to the floor.
Capacity 88 plates. Delivered in four units.

Event Sushi Conveyor for Hire

Choose from one of the following layout designs for your Portable Sushi Conveyor

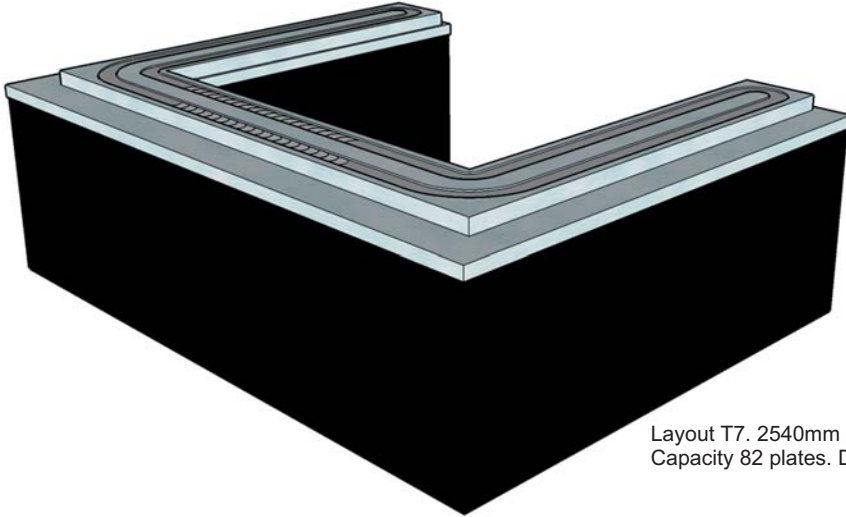

Layout T7. 2540mm x 3300mm x 2540mm, 600mm wide, 975mm to the floor. Capacity 82 plates. Delivered in five units.

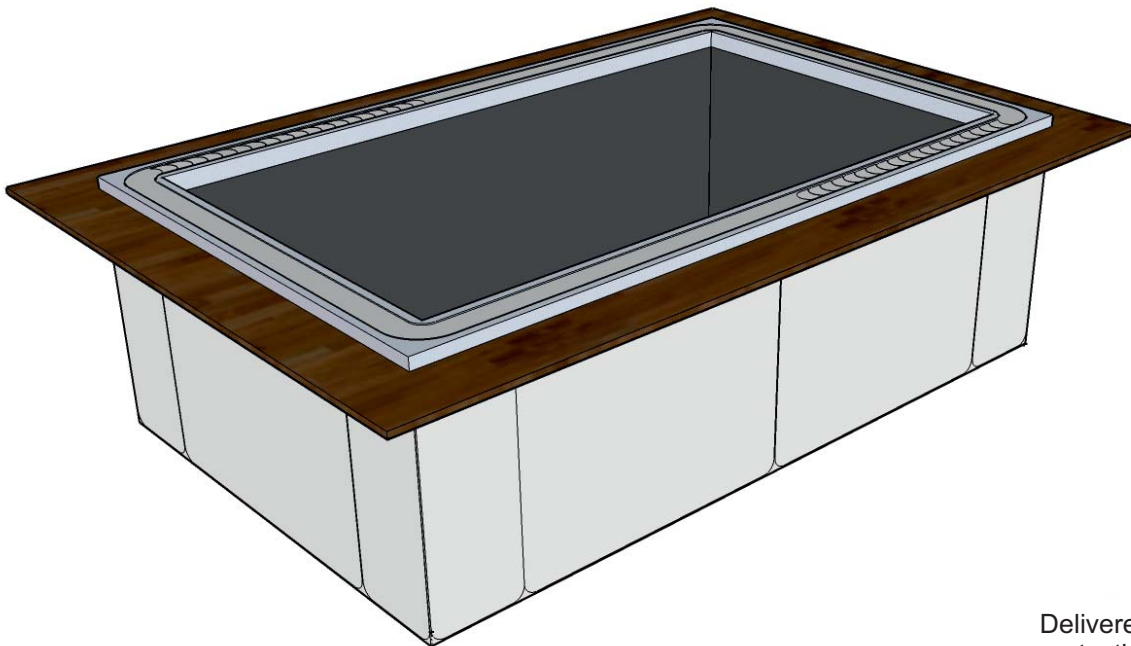

Layout E1. 2500mm x 2500mm single lane, 1050mm to the floor.
Layout E2. 3300mm x 2500mm single lane, 1050mm to the floor.

Delivered in protective bags.



we will deliver & set up the sushi conveyor at your chosen location in the selected layout. Our conveyors come in easily movable sections, transported in lightweight padded bags so access to rooms upstairs or in lifts is not a problem.

Sushi Plates, Dishes & Bar Stools for Hire

For the best presentation of sushi we can supply you with the following range of products in a variety of colours. Moulded in Melamine they are unbreakable in normal use and dishwasher proof. Minimum hire period 1 week.



Sushi Plate T14022W

White Sushi Plate with coloured outside and rim in blue, green, orange, pink, red & yellow. 140mm diameter x 23mm high.
Minimum order per colour 60

Price: £0.40 each per week.



Sushi Dish T L14038W

White Sushi Bowl with coloured outside and rim in blue, green, orange, pink, red & yellow. 140mm diameter x 23mm high.
Minimum order per colour 60

Price: £0.50 each per week.



Lid TC180L

Clear PC Lid for Sushi Plates Re-usable can be washed in a dishwasher. 130 x 58mm.
Minimum order 100

Price: £0.20 each per week.



Stools

Stools are also available for sale or hire please contact us for more information.

Available in two heights.

Add some movement to your party, event or promotion!

There are two types of conveyor and a number of layouts to choose from so that you can hire a conveyor to suit the space available. Our Portable and Event sushi conveyors are easy to transport and can be setup quickly by our staff. They are a very professional, completely free standing sushi conveyor system. They make a stylish center piece to any party; an eye-catching way of displaying products or a novel way of making your event that bit different!



Table height conveyor with stainless steel top & black curtain surround, which can be printed with company logos or themes if desired. A number of stylish layouts to choose from.

Sushi



Drinks



Products

